

# COIL SPRING COMPRESSOR

## KL-0015 For STRUTS PAT.

This tool can be used with impact wrenches, contains numerous patented safety mechanisms, and promotes fast, safe work (work time is reduced by anywhere from 30 minutes to 2 hours per strut!). Made by Klann of Germany!

- Ideal for BMWs!
- Design accommodates impact wrenches!
- Certified by German labor safety certification organizations!
- Comes with production indemnity insurance! Safety and operability are emphasized above all else. Only a German design could guarantee this level of human engineering!

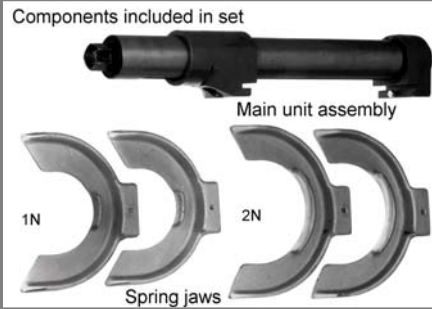

The dedicated KL-0055 pipe vise should be used to secure the strut main unit.



### TECHNICAL DATA & OPTIONAL PARTS

Work area (stroke): 50 mm ~ 345 mm  
 Spring jaw size (inner ~ outer diameters of applicable springs):  
 Size 1N: 80 ~ 165  
 Size 2N: 155 ~ 195  
 Size 0: 50 ~ 100  
 --- Option for Honda cars  
 Size 3N: 180 ~ 240  
 --- Option for Toyota MarkII 2.5-l cars  
 KL-1590-1 extension mount  
 --- Option for Nissan Primera cars  
 Max. safe weighting: 17,500 N  
 For cylinder rigidity, the special Rockwell 60 (900 ~ 100 HV) steel is used.  
 The jaw mounts and pistons are drop-forged.

**OPTIONS**

SIZE 0 HONDA  
KL-1500

SIZE 3N MARK  
KL-1530

**PARTS LIST**

- 9 C-ring A50
- 1 Cylinder
- 4 Jaw mount (movable)
- 15 Key
- 2 Drive shaft
- 12 Bolt 5x20
- 3 Jaw mount (fixed)
- 8 Bearing bushing
- 14 Press-fit pin 4x26
- 10 Bolt 5x45
- 11 Nut M5
- 6 Driver
- 5 Drive nut
- 13 Press-fit pin 6x26